

QD145 (1.45") Diameter Optical Encoder

Design Features:

- 500 kHz Fundamental Frequency Response
- Low profile, 0.87" assembled height
- Bearing design simplifies encoder attachment
- Resolutions up to 5000 lines per revolution direct read
- 4, 6 or 8 pole commutation
- Conductive carbon fiber housing
- Standard 1.812" Bolt Circle mounting
- Through shaft sizes up to 0.375" Diameter
- High Noise Immunity
- Cost Competitive with Modular Encoders



Description:

Quantum Devices, Inc. Model QD145 provides an improved feedback solution in applications typically using modular encoders. With an over all height of just only 0.87" and the stability of a bearing encoder design, the model QD145 can provide significant performance upgrades in applications limited by traditional modular encoder solutions. Outputs consist of a quadrature with reference pulse and three-phase commutation, which can be configured with either the industrial standard 5 volt RS422A Line Driver or the 5 to 26 volt OL7272 line driver. A flexible member allows for much greater tail shaft run out than can be tolerated by modular encoder designs, plus it provides 30 degrees of rotation for commutation timing. A housing constructed of conductive carbon fiber composite provides the EMI shielding of an all metal housing and the performance of a lightweight robust assembly.

Ordering Information:

QD145-05/05-1000-6-01-T3-01-02

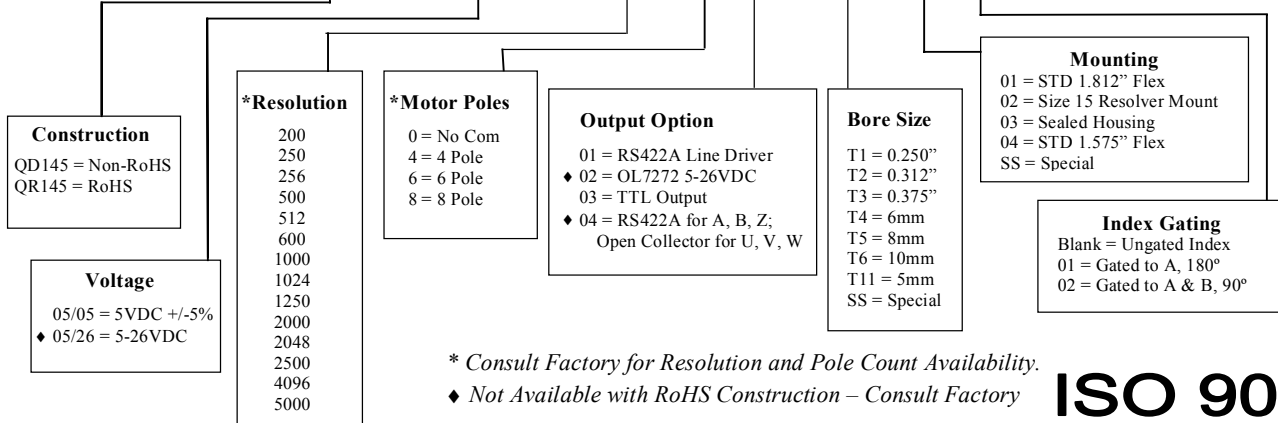

* Consult Factory for Resolution and Pole Count Availability.

♦ Not Available with RoHS Construction – Consult Factory

ISO 9001

CERT. NO. FM 52711

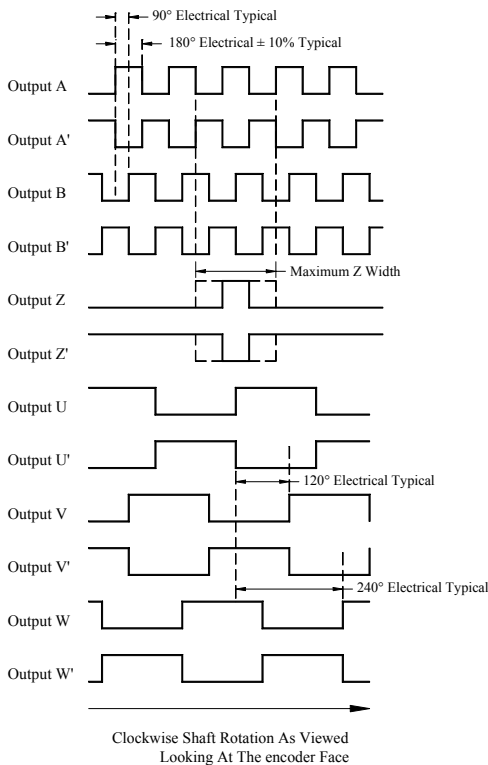

See figure below

Output Waveforms

Note: TTL Output Option consists of +VDC, Common, Case Ground and Output's A, B & Z wires only

QD145 Wiring Diagram

Red - +VDC
Black - Common
Brown - Output A
White - Output A'
Blue - Output B
Green - Output B'
Orange - Output Z
Yellow - Output Z'
Violet - Output U
Gray - Output U'
Brown/White - Output V
Red/White - Output V'
Orange/White - Output W
Yellow/White - Output W'
Black/White - Case Ground
Drain Wire - Cable Shield

Electrical Specifications

Input Voltage	5 VDC \pm 5% or 5-26 VDC
Input Current Requirements	125mA Typical @ 5VDC Plus Interface Loads
Input Ripple	2% Peak to Peak @ 5 VDC
Output Circuits	AM26LS31 RS 422A line driver OL7272 High Voltage Line Driver TTL Output
Incremental Output Format	Quadrature with A leading B for CW rotation with Index Pulse centered over A for 2500 line count and below. Index Pulse true over A and B High for 2500 line count and above
Frequency Response	500 kHz
Symmetry	180 Degrees \pm 10% Typical
Minimum Edge Separation	54 electrical degrees
Commutation Format	Three Phase 4, 6 or 8 poles
Commutation Accuracy	\pm 1° mechanical

Environmental Specifications

Storage Temperature	-40 to 125° C
Operating Temperature	-20 to 100° C Typical -20 to 120° C Optional**
Humidity	98% Non-Condensing
Vibration	20 g's @ 50 to 500 CPS
Shock	50 g's @ 11mS Duration

Mechanical Specification

Maximum Shaft Speed	8000 RPM
Through Shaft Diameter	0.250", 0.3125", 0.375", 6mm, 8mm, 10mm, 5mm (-0.0000, +0.0005)
Radial Shaft Movement	0.007" TIR
Axial Shaft Movement	\pm 0.030"
Housing	Carbon Fiber Composite (case ground via cable)
Housing Volume Resistivity	10 ⁻² ohm-cm
Termination	15 conductor Cable, 28 AWG 18" long, 9 conductor Cable for non-commutated and TTL outputs
Mounting	1.812" Bolt Circle
Moment of Inertia	1.5 x 10 ⁻⁴ oz-in-S ²
Acceleration	1x10 ⁵ Radians/S ²
Accuracy	\pm 1.0 arc minute

** Contact Factory for more information

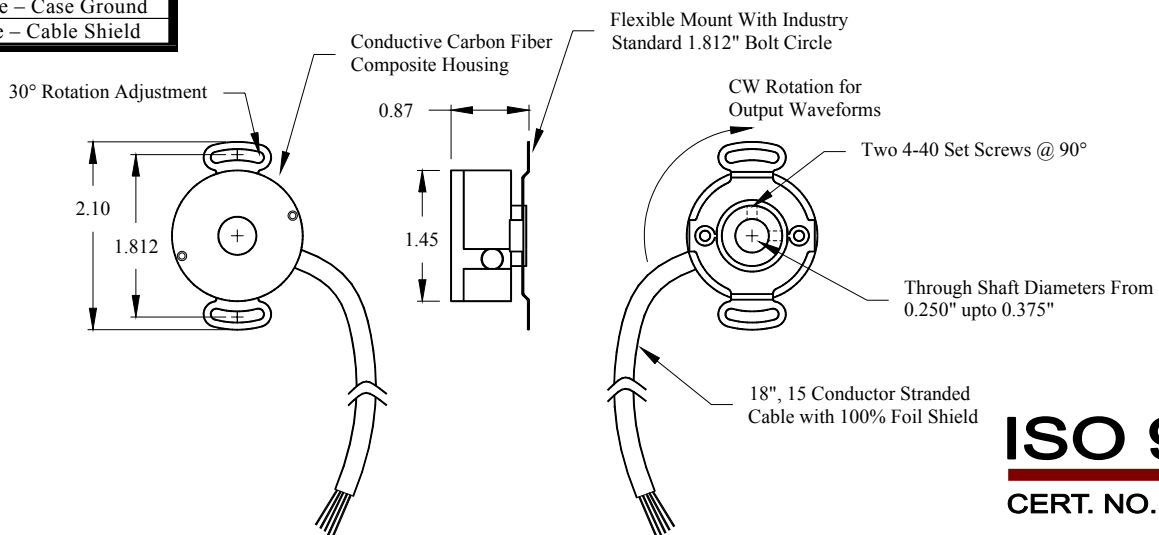

ISO 9001
CERT. NO. FM 52711

Quantum Devices, Inc. 112 Orbison St., P.O. Box 100, Barneveld, WI 53507